Lighting

Bright ideas for efficient illumination



Preface

Reducing energy use makes perfect business sense; it saves money, enhances corporate reputation and helps everyone in the fight against climate change.

The Carbon Trust provides simple, effective advice to help organisations take action to reduce carbon emissions, and the easiest way to do this is to use energy more efficiently.

This technology overview introduces the main energy saving opportunities for lighting and demonstrates how simple actions can save energy, cut costs and may increase profit margins.

Contents

Lighting controls:

Introduction

Lighting is something that most of us take for granted. How often do we question the amount or quality of that light? Or how much it costs to run and maintain?

This guide sets out to explain the basics of artificial lighting; the equipment, design principles and the effect it has on our work and leisure.

It is intended to inform a wide range of readers about the importance of light; both natural and artificial. In particular, it will help you to understand how to choose artificial lighting equipment that will deliver the most energy efficient solutions without compromising on quality.

A better understanding of good lighting practices helps when considering its direct and indirect costs.

A bad lighting scheme is a complete waste of energy and is not sustainable. This guide will explain why and help you to improve the lighting where you work, saving money and carbon.



Supplied courtesy of Zumtobel

The Importance of Light

Defining shape and form, light determines the way we think and how we interpret the spaces around us.

The quality of artificial lighting is one of the most important influences on performance in the work place. Some 80% of our sensory input at work comes through our eyes; compromising our vision is, therefore, not an option when considering energy efficiency measures.

It is vital to provide good quality lighting that is designed to match the tasks being undertaken and to respect the needs of the occupants.

And it is not only the visual effects of lighting that need to be born in mind; recent research has revealed that lighting has a clear impact on our health and well being in the work place. The right levels and the quality of light have been shown to affect alertness and accuracy at work.

Lighting uses some 20% of the electricity generated in the UK; and over 75% of lighting installations are thought to be out of date and unable to meet current design standards.

The need to reduce carbon emissions presents an opportunity to make lighting more efficient and more effective; so long as the right decisions are made when selecting new lighting.

Understanding light

Light travels at approximately 700 million miles per hour and from leaving the sun, it takes around eight minutes to reach the surface of the earth.

Light is electromagnetic radiation. Light visible to humans though is only a tiny proportion of the whole electromagnetic spectrum as shown in Figure 1. In fact the visible part of the spectrum ranges from just 350nm-780nm – just 400nm out of over 5 million!

Just outside of the visible part of the spectrum lie infrared and ultra-violet light. These terms are probably familiar and with special equipment, we are able to 'see' these areas of the spectrum too.

Our eye-brain system is a highly sophisticated system of data transfer. When light enters the eye, we have a number of receptors which absorb the information they are receiving and pass information to our brain.

We have three receptors in our eye: rods, cones and ganglion cells. Rods detect shape and form but are monochromatic. Cones enable us to see and distinguish colour so someone who is referred to as 'colour-blind' has a deficiency of cones. They can usually see colour but have difficulty in distinguishing between some colours, especially red and green.

The third receptor, the ganglion cell is a relatively new discovery and this is entirely light-responsive. It doesn't aid our vision but does inform our brain whether it is light or dark. This controls our circadian rhythm, our daily cycle of awake and asleep. Cortisol, our in-built stress hormone, responds to light and rouses us into a state of alertness. Over the course of the day, the sleep hormone, melatonin, secretes into our system and generates a dip in our alertness around

lunchtime. Exposure to a high level of light at this time, a walk in the sunshine for example, is enough to boost the cortisol levels again and we become alert once more.

More information about the effect of light on health and well-being can be found on [page 11](#).

Figure 1 Electromagnetic spectrum

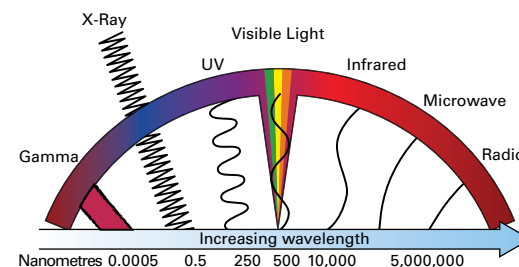

Light & colour

MENU

There are two very important aspects of light relating to colour which are often referred to but not always understood: colour temperature and colour rendering. They are both properties of lamps but have very different meanings and implications.

Colour temperature is the way that the colour appearance of a lamp is defined. It is measured on the Kelvin scale and is based upon the reaction of a black body radiator. Imagine placing a poker into a fire, as the temperature of the poker increases, it changes colour. As it starts to warm, it glows red, moves through orange and yellow and eventually appears almost blue-white at a very high temperature. The Kelvin scale of colour temperature reflects these appearances and we refer to low colour temperature as being warm in appearance and high colour temperature as cool in appearance.

Figure 2 Colour temperature

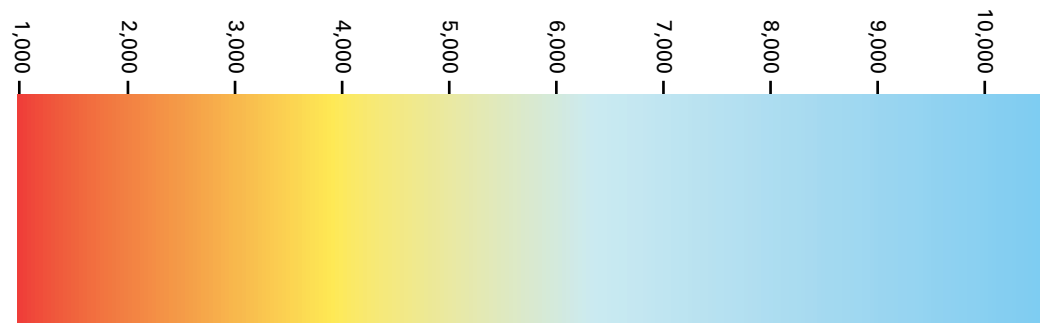

Colour rendering is the term used to define the ability of a lamp to show colours effectively. For example, when buying clothing, items can look like one colour in the shop and then a quite different one at home. This will be due to the difference in colour rendering properties of the shop and your home lighting.

Some lamps are able to render colours perfectly, exactly as they would be seen in natural light but others have very poor colour rendering properties. For example, High Pressure Sodium lamps are highly efficient light sources but have very poor colour rendering.

Figure 3 Example of effect of colour rendering

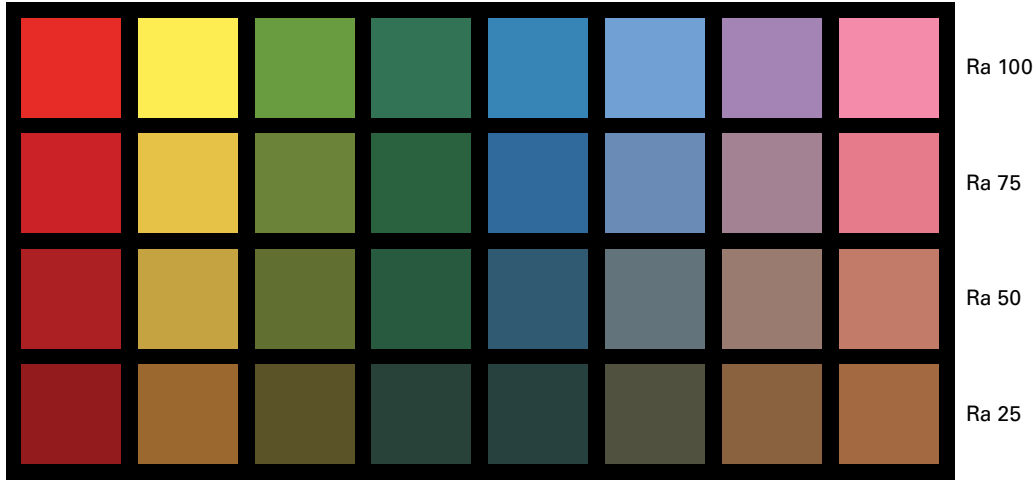

The colour rendering properties of lamps are measured using the 'Ra Index'. This relatively simple index ranges from 1 to 100 with an Ra of 100 being perfect. Figure 3 illustrates how different Ra index values affect the appearance of colours.

Although good colour rendering is not always essential, it is important to have it above Ra80 in most interior spaces and in retail it is very important. Externally, it is important for sports lighting but less so for street lighting.

MENU

Daylight

Daylight is the only freely available light source and yet all too often it is overlooked; well controlled daylight can provide a space with the best possible lighting effect, superb colour rendering, great user comfort and with zero cost or CO₂ emissions.

Research has demonstrated that daylight has tremendous physiological and psychological benefits; bringing daylight into hospitals can speed recovery and in schools it can help with concentration and improve learning so why don't we make more of it?

The argument is that using daylight successfully within buildings is not always simple or straightforward; problems such as heat gain and glare from direct sunlight can be avoided both at the initial design stage and subsequently with shading devices. Daylight can be brought into spaces through roof lights, atria and light guidance systems as well as windows. [View our animation on how to maximise daylight in your buildings.](#)

Lightly coloured walls and ceilings will aid the distribution of daylight in rooms while architectural light wells can aid daylight penetration further into the building.

Artificial lighting is still needed of course, but by ensuring it is linked to the daylight availability, it will be used most efficiently.

Successfully managing the balance of natural and artificial light is key; whilst it is possible for artificial lighting to be completely off when there is sufficient daylight in a space, consideration must be given to what happens when that changes; a sudden change of lighting level through the artificial lighting all coming on (or turning off) at once, creates distraction and discomfort. So artificial lighting should be dimmed to balance the daylight and deliver a constant light level for the users.

Figure 4 Switching in parallel

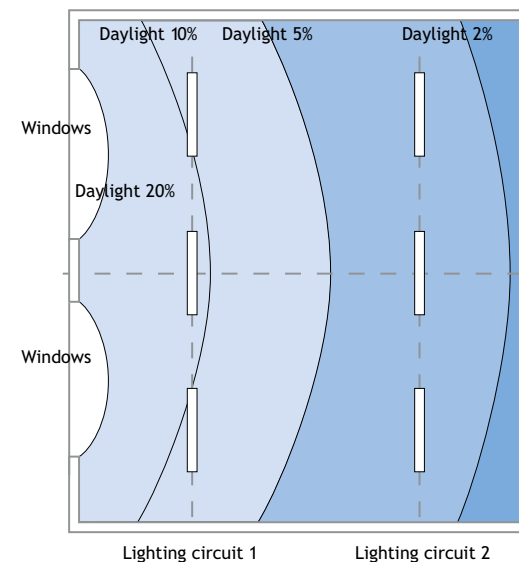

It is also important to consider the colour temperature of the artificial lighting; daylight generally appears to be cooler than most artificial light sources so this needs to be taken into consideration when managing a mixture of natural and artificial light because excessive contrast may cause discomfort.

MENU

Did you know?
In a study in California it was found that retail stores with roof lighting had higher sales figures than those without.

Figure 5 Effect of rooflights with automatic lighting control systems on total energy consumption

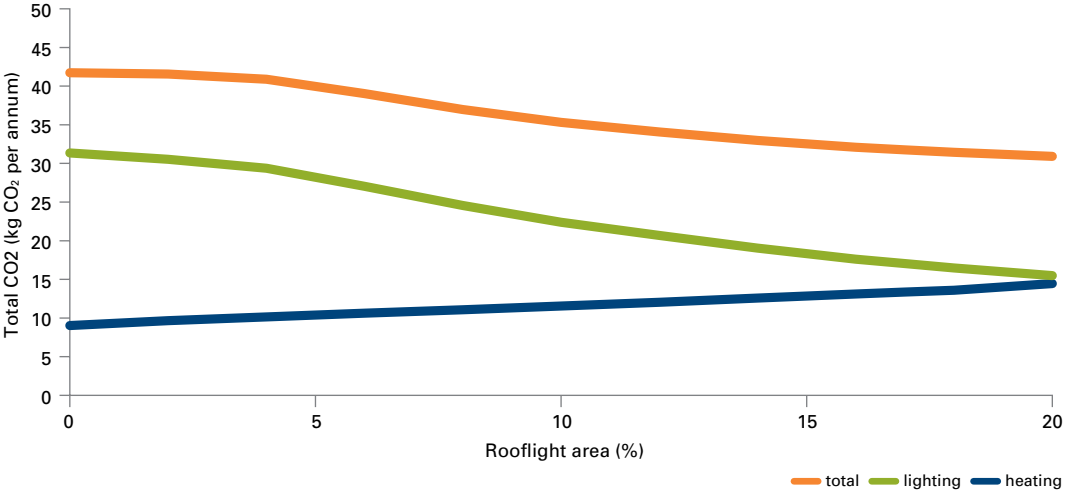

Data is courtesy of the National Association of Rooflight Manufacturers

Health & Well-being

Lighting impacts upon our ability to work accurately and effectively.

The most important objective with lighting of a workplace is to satisfy the needs of the staff by giving them a comfortable and productive space.

By getting the lighting right, staff will be more comfortable in their working environment and they can become more productive. Of course the converse is also true so energy-saving measures which compromise the quality of the lighting is short-sighted and unsustainable.

Almost without exception the highest fixed cost in any business is staff; salaries and associated

employment costs can be as much as 70% to a business, so although lighting represents a large proportion of the electricity bill, the electricity cost in relation to staff is often very low.

Both natural and artificial light influence our health and well-being; light directly affects our mood and alertness and can also impact our sleep patterns.

The non-visual receptor in our eyes responds to light and controls our levels of the key hormones: cortisol, melatonin and serotonin.

Cortisol is commonly referred to as the stress hormone; it triggers our levels of alertness and energy. When we have high levels of cortisol, we are alert and energetic; if these levels drop, we lose concentration.

Melatonin is the sleep hormone; high levels of melatonin help us to sleep; prolonged suppressed levels of melatonin can cause insomnia.

Serotonin is our 'happiness' hormone, our mood hormone. A deficiency of serotonin will adversely affect our mood. Serotonin is produced by the brain when melatonin levels are low.

The secretion of these hormones follows a daily cycle (shown in Figure 6 on the right) in response to the natural light-dark of the day.

If light levels are too low the sleep hormone, melatonin, is not suppressed and we don't produce serotonin. This is why we can feel sleepy or a bit down in a dim environment; think of a how you feel on a grey, misty, November day and compared with a bright, sunny, day. The higher light levels of the latter are stimulating our alertness and happiness.

Research is continuing into the effects of both light levels and the colour qualities of the light but results to date have indicated that benefits to mood, productivity, alertness and sleep patterns can be realised through adjustments to lighting.

Figure 6 Human circadian rhythm

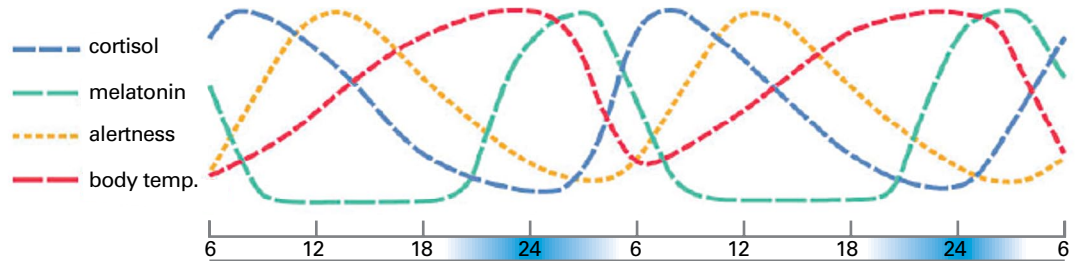

Data from Surrey University

Lamps

Light sources are called lamps, rather than light bulbs, and each lamp type has different characteristics which affect where and when they should be used.

The most important three characteristics are the efficacy (how efficient the lamp is), its expected lifetime and its colour rendering ability.

Artificial light can be created in different ways:

Incandescent: where light is created by passing an electrical current through a wire so that it glows white hot. (e.g. Tungsten)

Discharge: the generation of light occurs within a gas filled envelope that is driven by an electric circuit. (e.g. Fluorescent)

Solid state: light being generated at the junction of a semi-conductor (e.g. LED)

Although there are some other methods, these cover over 99% of currently used lamp technologies.

Incandescent

Invented well over 100 years ago, incandescent lighting today is largely restricted to domestic use and display lighting in shops, hotels and restaurants. They have a short lifetime but do offer good colour rendering. They are also – in the most part – easily dimmed.

Many incandescent lamps are currently being phased out of the market because they are so inefficient.

However, there are some incandescent lamps which are more efficient thanks to the addition of halogen within the glass surrounding the tungsten element. In recent years, the low voltage versions of tungsten halogen lamps have had their efficacy improved by around 30%.

Did you know?

Lamps have to carry an energy-efficiency label (see [Figure 8](#)). Used on domestic white goods for years, these display clearly how efficient the lamp is. These are now being used on most electrical products.

Figure 7 Incandescent lighting

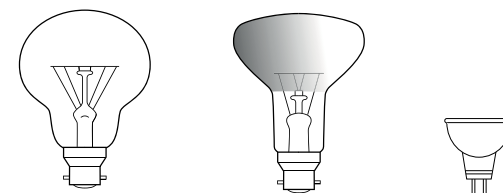
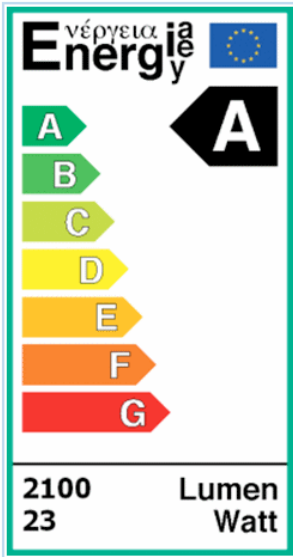

Figure 8 EU Energy Efficiency Label for Lighting



MENU

Discharge lighting

Most commercial lighting relies on a range of lamps that use glowing gas discharges and phosphors to create light. Examples of lamps that use this process are:

- Fluorescent
- Low pressure sodium
- High pressure sodium
- High pressure mercury
- Metal halide
- Ceramic metal halide.

Most discharge lighting is characterised by its need to 'warm up' as they do not come on instantly at full brightness. This is called the strike time, which can vary from a few seconds to many minutes with some types.

Additionally, some types will not 're-strike' when they are hot, so if a lamp is switched off, it then cannot be turned back on immediately; this affects their controllability.

Fluorescent

By far the most common form of discharge lighting, fluorescent lamps are supplied in tubular or compact forms.

The warm up to full brightness is quick; usually less than one minute. It is an efficient source, with typical efficacy around 80 lumens per watt and fluorescents have good colour rendering ability. The lifetime varies over quite a broad range, with compact fluorescents typically from around 6,000 hours while the tubular versions start at around 12,000 hours, although there are long life tubular versions rated at 70,000 hours.

Figure 9 Discharge lighting

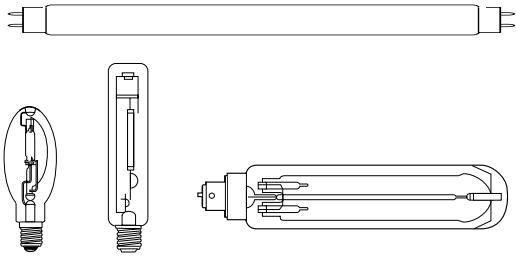

Did you know?

Until recently lamps were labelled by their wattage, but this only tells us how much power it uses. Now, all lamps are labelled by their light output, which is expressed in lumens.

Fluorescent lighting is also the most easily controlled of this type of lamp. They can be switched on and off quite readily, and with the right control gear they can be successfully dimmed.

Low pressure sodium

A highly efficient lamp, these are almost exclusively used in street lighting. These are the familiar orange lights that seem to turn all colours a dirty brown.

Although they are still the most efficient light source they are progressively being replaced by other lamp sources because they take up to ten minutes to reach full output and cannot be dimmed.

High pressure sodium

These lamps are easily identified as the bright golden street lights on many of our motorways; they are also often used in warehouses and floodlighting.

They have a high efficacy of 125 lumens per watt and a lifetime around 20,000 hours. However, they have poor colour rendering and take a long time to reach full brightness.

As a result they are not easily switched ON and OFF; although, with the right gear they can be dimmed to a limited degree.

High pressure mercury

These lamps are not commonly used in the UK. They produce white light with a bluish tinge. They are not very efficient and have poor colour rendering. Any installations using these lamps should be considered for refurbishment.

Metal halide and ceramic metal halide

This group of lamps offers a highly efficient source, typically 80 lumens per watt, in a very large range of power ratings.

They have colour rendering from Ra60 right up to Ra90 or more and a lifetime typically around 12,000 hours.

Figure 10 Metal Halide lamps used for sports lighting



Image courtesy of Thorn Lighting

Control gear

Most lamps require an additional piece of equipment to help them run; sometimes called a ballast or driver, but widely described as control gear.

In a similar way to laptop power supplies, the control gear transforms the 230v mains electrical supply into one which the lamp requires.

Early control gear used wound components and were referred to as 'magnetic'. They were very inefficient although the technology has improved with time, losses are still significant. A further drawback to magnetic gear is that it causes lamp flickering (100Hz) which induces headaches for some people.

Electronic control gear entered the market, initially for fluorescent lamps, and was able to improve the quality of artificial light; by driving the lamp at a higher frequency (HF) with no perceptible lamp flicker.

HF control gear is also much more efficient; it can effectively produce more light with less power than previous magnetic designs.

The role of the control gear includes the preservation of its lamp. Lamp life is an important factor in the whole life cost of a lighting installation. Changing lamps is a costly and time consuming exercise so the development of control gear to extend lamp life is highly beneficial.

The move to electronic circuits was the key to introducing practical dimming to fluorescent, and latterly high intensity discharge (HID) light sources. It is worth noting, though, that not all HF gear can be dimmed.

Figure 12 Magnetic and electronic control gear



Images courtesy of Philips Lighting

Dimmable HF gear can control the output of a fluorescent lamp smoothly between 1% and 100%. It requires additional control cabling to operate the dimming function and the type of control gear driving the lamps is a significant influence on the choices that can be made when introducing a lighting control system.

The arrival of LEDs has not removed the need for control gear; LEDs still need specific power supplies, often referred to as 'drivers'. Like other control gear, they are required to deliver the correct voltage and current to the LED devices. In fact the quality of an LED driver can have a significant affect on the LED performance.

Figure 13 Electronic ballast v. conventional (HID)

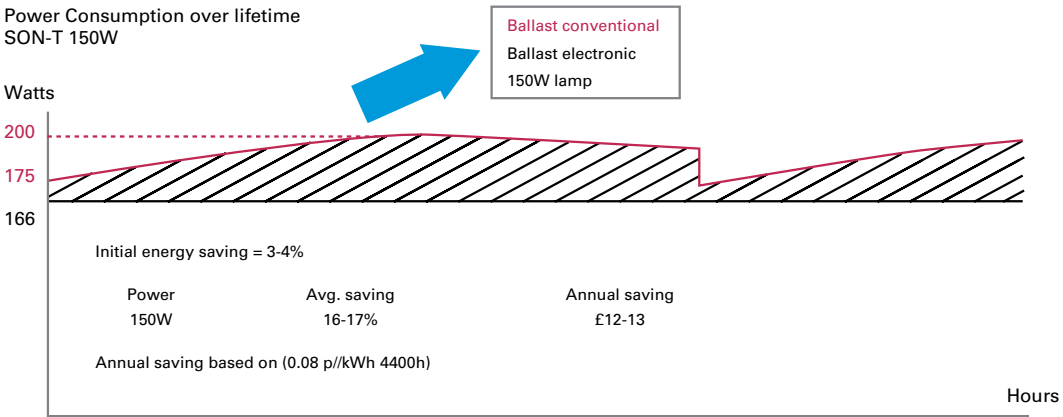

Data courtesy of Philips Lighting

Did you know?

Electronic control gear has significantly improved the efficiency of artificial lighting. However, the introduction of Digital Addressable Lighting Interfaces (DALI) and the use of lighting controls means that the standby and parasitic power losses of this equipment must also be minimised.

Luminaires

Whilst lamps are the light source, these are housed in fixtures called luminaires.

There is a huge range of luminaire types and designs, each with their own characteristics. It is helpful first to understand the components which make up a luminaire and how energy is used by these.

There are five principle components in a luminaire: housing, control gear, lamp holder, lamp and reflector. Some luminaires will also have a diffuser.

In most luminaires, not all of the light emitted by the lamp is emitted by the luminaire. This is due to losses caused by inter-reflection and absorption.

Figure 14 Line drawing of luminaire showing components

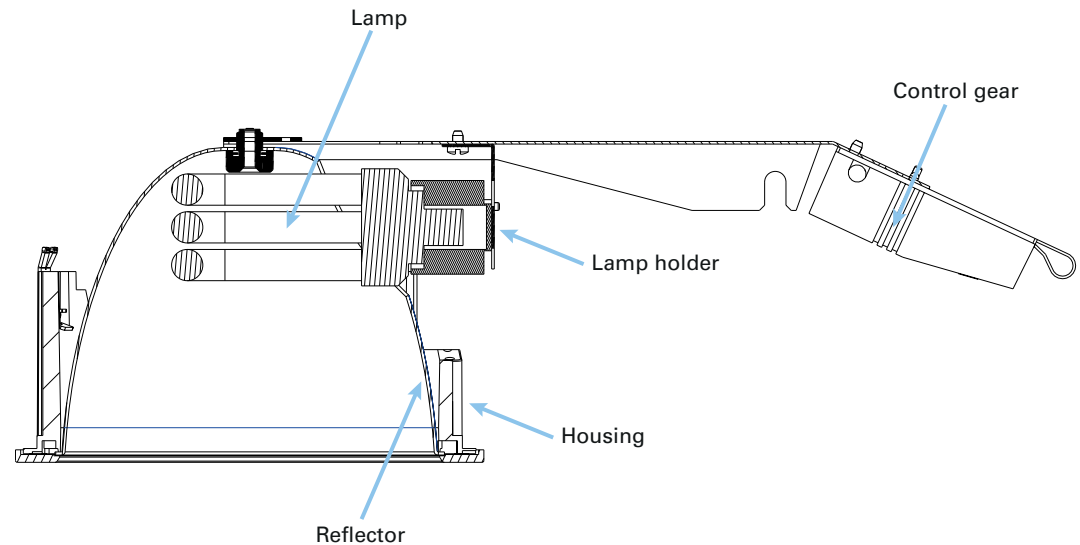

We can measure the effectiveness of the luminaire performance by comparing the total light emitted by the luminaire with that of the bare lamp. This is referred to as the Light Output Ratio (LOR). The higher the LOR, the better the luminaire performance.

Each type of luminaire will have different performance characteristics but the LOR will also vary from manufacturer to manufacturer depending upon the optical design and also quality of materials used.

Material within luminaires which directs the light beams can vary in its reflecting ability from 0.5 for a satin chrome material to 0.9 for an aluminium material with a silver coating so the LOR in luminaires using these materials will vary enormously.

The most typical luminaires used in commercial properties can be summarised as:

- Modular
- Downlights
- Pendants
- Spotlights
- Wall lights.

On the following page is a summary of these luminaire types, their typical performance and common application areas. It is worth noting at this stage though that some luminaires are designed for a specific purpose and utilising them more generally is not advisable.

The requirements for lighting offices and other areas where display screens are used, need careful treatment and luminaires should be designed to avoid glare onto the screen which would affect the users.

Equally, ensure that there are high levels of visual comfort in the space by illuminating the walls and ceilings so that the user's whole visual field is considered and not just the desk. These office luminaires are often inappropriately used in other areas such as retail environments.

Figure 15 Modular luminaires with reflector



Image courtesy of Thorn Lighting

Mounting: Surface, Recessed
 Lamp types: Fluorescent
 LOR: 0.6 – 0.9
 Applications: Office, IT areas

Figure 16 Modular luminaires with diffuser

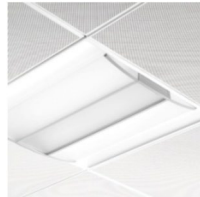

Image courtesy of Thorn Lighting

Mounting: Surface, Recessed
 Lamp types: Fluorescent
 LOR: 0.5 – 0.9
 Applications: Office, Retail

Figure 17 Downlights



Image courtesy of Thorn Lighting

Mounting: Recessed
 Lamp types: CFL, Tungsten halogen
 Metal halide, LED
 LOR: 0.6 – 0.9
 Applications: Circulation, Retail

Figure 18 Pendants



Image courtesy of Thorn Lighting

Mounting: Suspended
 Lamp types: Fluorescent, Metal Halide, HPS
 LOR: 0.5 – 0.9
 Applications: Office, Industrial, Retail

Figure 19 Spotlights



Image courtesy of Zumtobel

Mounting: Surface, Track
 Lamp types: Metal halide,
 LED Tungsten Halogen
 LOR: 0.8 – 1.0
 Applications: Retail

Figure 20 Wall Lights



Image courtesy of Thorn Lighting

Mounting: Recessed, Surface
 Lamp types: CFL, Metal halide, LED
 LOR: 0.4 – 0.6
 Applications: Office, Circulation

Lighting controls: overview

Lighting controls can make huge reductions in energy use, usually between 30% and 50% in a typical office environment.

It does not matter how efficient a luminaire might be if its use is uncontrolled; there will still be waste, avoidable costs and unnecessary CO₂ emissions.

Lighting controls are the key to managing the use of light and to ensure that the right light is provided in the right place and at the right time.

Artificial lighting can be switched off or dimmed, both when there is sufficient daylight and when there is no-one there to benefit from its use. The light level may also be varied according to the needs of a task or activity. Properly applied lighting controls facilitate this and ensure that there is no unnecessary use of electricity.

Automated functions should be combined with user controls to optimise performance; light and movement sensors can monitor daylight and occupancy and a time clock can manage overall operating hours; but giving users of the space

Figure 21 Emissions by building type and end use (MtCO₂)

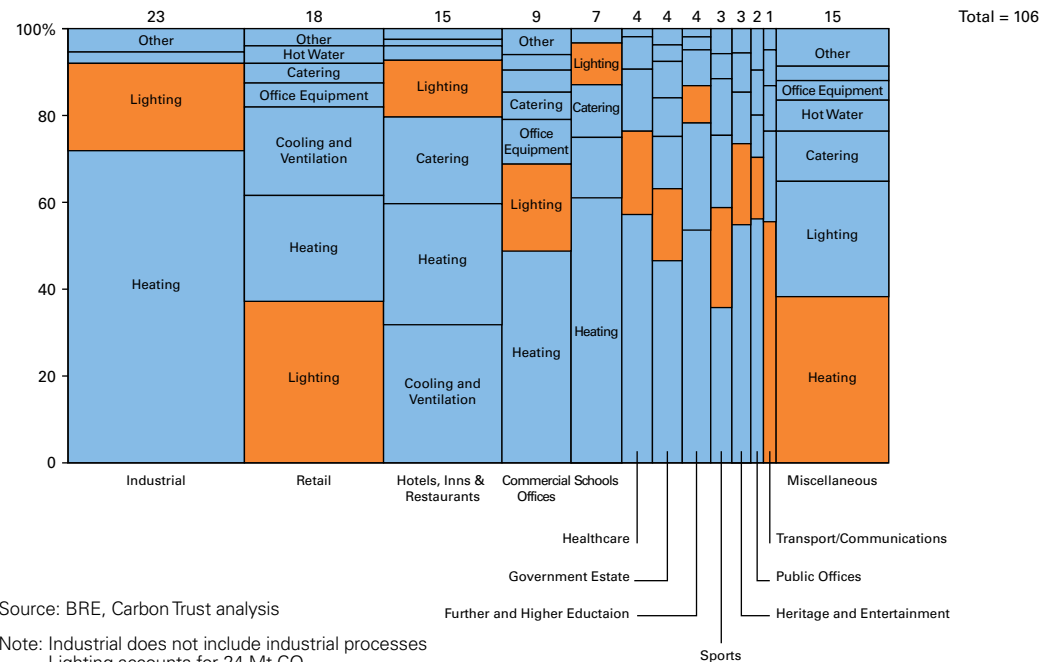

Source: BRE, Carbon Trust analysis

Note: Industrial does not include industrial processes
Lighting accounts for 24 Mt CO₂

some control is also valuable, we all like to be able to make decisions for ourselves.

These user controls must be easily understood and conveniently located. Wherever there might be doubt then clear labelling should be employed.

The principle of combining user controls with automatic management is to have an environment where users switch lighting on but it is switched off automatically when it is no longer required.

Generally, we're quite good at switching lights on when we go into a room but less so at switching off when we leave. This approach needs someone to make a decision to switch the lighting on but then the controls automatically reduce the light level and switches off when there is sufficient daylight or when users leave the room.

There is clear evidence that giving people more control of their lighting conditions also contributes to their perception of comfort. And in those buildings where there is a high ratio of local switches to lights less electricity is used. Comfort and lighting energy efficiency have been shown to go hand-in-hand.

Figure 22 User controls



Image courtesy of Philips Dynalite

Lighting controls: techniques

Automatic lighting controls generally react to three main stimuli:

- Movement sensor – occupancy control
- Time clock – timed schedule
- Light sensor – daylight linking.

There are additional functions in some lighting control systems but these are the principle techniques for reducing electricity use.

Motion sensors

Motion sensors monitor occupancy. They rely on three technologies to detect presence:

- Passive infra red – PIR
- Ultrasonic detection
- Microwave detection.

PIR sensors are the most common type used in office spaces because they offer a good compromise between value and sensitivity. They can generally monitor smaller areas than the other two methods which can be beneficial.

The location of a movement sensor is important; it must be able to 'see' the activity that requires the light but not beyond that area. Many sensors do not work effectively because people passing close by trigger the lighting to come on when it is not actually needed.

The table on [page 25](#) was originally developed some years ago by the Building Research Establishment (BRE Digest 498 – Selecting Lighting Controls) in order to help people understand how lighting controls in any given space might be applied. A similar table appears in the Building Regulations.

If a room is 'owned' by a single occupant then it is reasonable to pass responsibility for lighting control to that individual. Once a space is 'shared' it then becomes more complicated because the occupants may have different lighting needs. The 'type' helps inform the application with regard to the best choice of local controls.

Movement sensors can be used in two, different, modes – 'presence' and 'absence' detection. Presence detection automatically brings on the light as soon as it senses movement; and switches the light off when the space is vacant. Absence detection lighting must be switched on manually and the sensor then switches the lighting off when the space is empty.

Figure 23 Some typical movement sensors



Time control

Whilst timed operation used to be an effective method to control lighting based on predicted occupancy levels in buildings, this doesn't fit so well with modern, flexible working practices. To have any chance of success there needs to be a very large number of local overrides that are easily found and used. The need for these can mean that systems that rely only on scheduled switching actually use more energy than a manually operated installation.

In modern, networked control systems time scheduling is now used to change the overall operating mode. The behaviour of other controls may need to be different at certain times of day. They do, however, remain vital in exterior lighting so lights are only on when it is dark outside.

Table 1 Defining spaces and appropriate controls

Type of space	Examples	Controls
Owned	Cell office, small workshop, consulting room.	Wall switch, movement sensor; preferably in combination (absence mode).
Shared	Open plan office, production area, ward.	Wall switches, movement sensors, photocell; local and remote operation; combined.
Temporarily owned	Meeting room, 'hot' office, classroom.	Wall switch, scene plate, movement sensors; preferably in absence mode.
Occasionally visited	Store room, book-stack, toilet.	Wall switch (with time delay), movement sensor; auto operation OK.
Un-owned	Corridor (open or closed), stairs.	Remote manual or automatic operation, movement sensors; linked to work area lights.
Managed	Hotel lounge, museum, foyer, terminal.	Remote manual and automatic operation; time scheduling.

Figure 24 Light sensors

Image courtesy of Zumtobel



Image courtesy of Philips Lighting

Light sensors

The technologies used to detect light are, in the main, less important than the way they are used.

Light sensors are commonly used in two ways. They can be used to observe the external (natural) lighting conditions and hence be a reference level for the control system to act upon. Or they can be mounted in the ceiling to observe the lighting conditions immediately below.

The use of an outward looking sensor is usually made in applications where a lot of daylight is coming into the building and the control function is limited to switching only.

It works on the principle that the amount of daylight penetrating the building will always be directly proportional to the current ambient light. The system then makes decisions about calculated levels of light in various parts of the building.

Downward facing, ceiling mounted light sensors are usually used in office spaces where the intention is to use dimming control to integrate the artificial and natural lighting. As daylight increases the sensor automatically reduces the amount of artificial light.

It is generally better practice to use dimming controls when adjusting the lighting in response to daylight. The light level in any space will be the sum of the natural and artificial light. If the light level was 1000lux, with 500lux provided by the artificial lighting, then a switch off will halve the lighting level and occupants may think the light level is too low. The reaction will be to restore the artificial lighting even if it is not required.

Figure 25 Interior making use of good daylighting

Image courtesy of Thorn Lighting

Lighting controls: applications

Lighting controls may also be categorised by type and application:

- Self-managed luminaire
- Stand alone
- Room based
- Scene setting
- System.

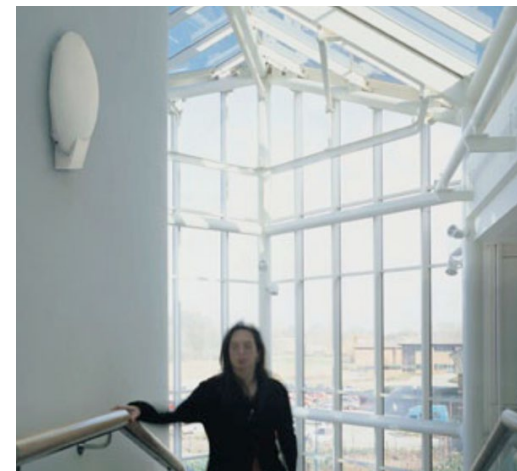
Self-managed luminaire

Some luminaires are supplied complete with an integral controller; this may be a movement and/or light sensor. Sometimes called intelligent luminaires these products are suited to small rooms and any application where each light may be operated alone.

Stand alone

A 'stand alone' lighting controller is usually a self-contained device that comprises a sensor and actuator. In most cases the two parts are integrated into one physical package. These controls are independent from each other and well suited to individual spaces like store rooms and toilets.

Room based

As the name suggests, these products have been designed to offer convenient control schemes for one room or area. The most common application is a classroom or meeting room and the solution may contain a number of components, depending on the size of room and control needs.

Scene setting

When lighting controls are provided for the primary purpose of comfort and ambience then a 'scene setting' system is required. Frequently these products are manually operated and appear in lecture theatres, restaurants and hotels.

System

A lighting control system is usually a building wide application. That means all the lighting is effectively linked together and managed as a whole.

A full, networked, lighting control system has additional components to the sensors already described.

Depending on the installation and application a lighting control system may comprise:

- A central supervisor
- Area or zone controllers
- Lighting Control Modules (LCMs)
- Lighting control or Dimmer panels
- Sensors
- Control or scene setting switches.

Generally the components are designed to help the system to be included within the lighting installation infrastructure.

Their function and performance varies from supplier to supplier but their purpose is to make each system robust in use and easy to install. See [How to implement lighting controls \(CTL161\)](#).

Figure 26 Typical graphical user interface provided with a lighting management system

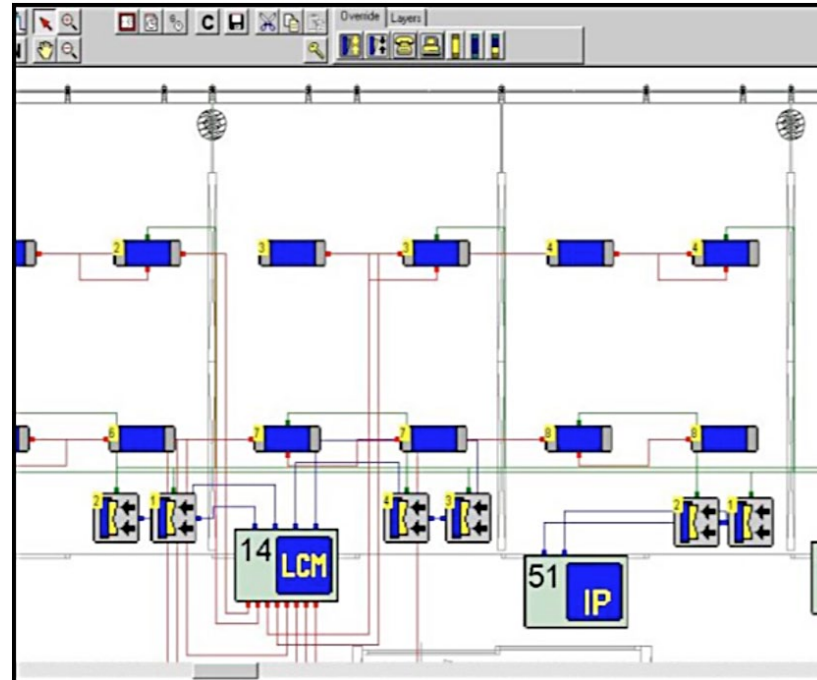

Image courtesy of Philips Lighting

Lighting design

What is lighting design and how does it fit into the overall picture?

In its simplest form, lighting design is the selection and placement of the lighting within a space.

Ask any lighting designer what lies behind good lighting design and you'll get the same response:

It's the right light, in the right place, at the right time.

Arguably the most crucial of these, from an energy management viewpoint, is the timing. It doesn't matter how efficient your lamp or luminaire is if it is on at 2am in an empty office. 'At the right time' means it is switched off when there is no need for it to be on.

Whilst lighting design is often optimised for new buildings, it is equally relevant for existing buildings.

Lighting design draws together the four key components:

- Lamps
- Control Gear
- Luminaire
- Controls.

Each of these components is explained in greater detail elsewhere in this guide, but whilst each component has its own level of efficiency, when they are brought together in a designed solution, they will combine to provide even greater efficiencies.

The lamp, control gear and luminaire combine to provide the first of our answers to good lighting: the right light.

This takes the form of an appropriate luminaire operating with its control gear and lamp combination to deliver the right amount of light for the purpose of the space.

The essential premise is that less light is required in a corridor than in an office, so getting the right amount of light is important.

The design of the layout of the luminaires will ensure that the light is delivered in the right place.

It is important to only deliver light to where it is required; if a cellular office has one desk, then the light needs to be delivered to the desk and not the surrounding carpet!

Figure 27 Lighting left on in an empty office



Did you know?

The delivery of light at the right time comes entirely down to the lighting controls and these can ensure that images such as the one above do not occur.

How much light?

If the essence of good lighting design is about delivering the right light, in the right place, at the right time, then how do you decide on how this is achieved?

The demands for light vary according to the people who are in the space and what tasks they are completing.

In order to decide how much light you need and where you need it, ask the following questions:

- Who is using the space?
- What are they doing?
- When will they be there?
- How long will they be there?

Let's first address the question of who is using the space.

The reason it is important to know this is because our eyesight deteriorates with age. Irrespective of other eye conditions, the visual ability of a 10-year old child is hugely heightened when compared to that of a 50-year old. Because of this, younger people need less light to perform the same task.

Figure 28 Multi-functional lighting required



More often than not, there will be a mix of age ranges in any given space. This is true, albeit to different degrees, whether it is an office or a school and this variance may change during the course of the day.

For example, a school may be used predominantly by children for most of the day but by adults attending night classes in the evening.

Knowing who is using the space will help us decide on the lighting requirements, in the example of the school, we may need to allow for the lighting to be changed.

The second question is arguably the most important, the one which addresses the tasks in hand. The reason that we need to know this is because our demand for light varies with what we are doing. Walking down a corridor is a much simpler visual task than reading a book. In an office, we might need less light to look at a computer than to read a printed report.

Detailed guidance for the lighting level required for different tasks can be found in the Society of Light and Lighting's Code for Lighting.

Figure 29 *Lighting levels required to perform a task vary with age*

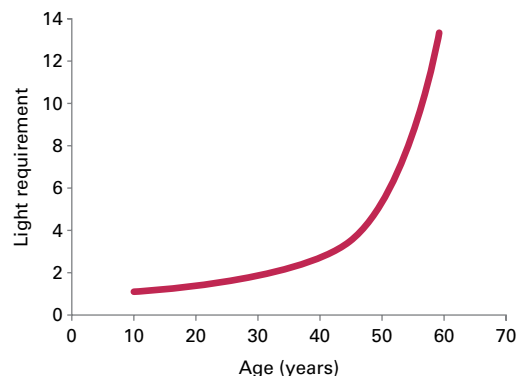

Objectives & considerations

Whilst establishing the right light level for the application is an important part of the lighting design process, there are other key objectives and constraints to consider.

We may wish to add some lighting purely for visual interest. This might take the form of wall lights, spotlighting or even the inclusion of colour.

Whilst it may be considered to be superfluous, particularly in an energy context, visual interest can prove a valuable additional benefit for the people who use the space.

People generally prefer to sit in front of a window and although the view itself may not be spectacular, the interest created allows our eyes to relax and regenerate.

Additional lighting to create visual interest can achieve the same objective and this variety can reduce eyestrain and headaches.

More information on this intangible benefit can be found on the next page.

However, one of the biggest hurdles we often face in the design process is that of the architecture of the space.

Figure 30 *Wall lights provide visual interest*

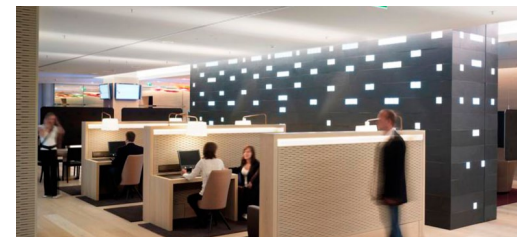

We can look ideally at a combination of light sources and luminaires which we might want to include as part of the solution but invariably we have to fit the solution around the ceiling type, layout and other features such as pillars.

Many buildings now have suspended ceilings with 600mm x 600mm ceiling tiles and whilst these enable all the building services to be concealed, they can start to dictate lighting design to the detriment of the users.

At all times we must be mindful of the demands of the people in the building that we are lighting. In some older buildings, concrete slab ceilings are more prevalent and this can lead to restrictions with wiring.

It may appear cumbersome to replace existing wiring arrangements but it should still be considered as the benefits of making a deeper refurbishment can more than outweigh the cost and inconvenience.

Rather than considering the building architecture as inhibiting, we need to embrace it, adding wall lights to pillars, creating opportunities with the ceilings for additional details such as cove lighting and utilising the flexibility of lay-in ceiling grids to their maximum scope.

What we must ensure at this stage is that we are using the right luminaires to fit all the objectives and constraints.

In the detail

It is important to create visual interest in any space, but particularly on the walls, for the comfort of the users of the space.

Many people will experience eyestrain when working at a screen for long periods of time, in fact concentrating on any specific task for too long will cause the same effect.

In addition to the benefits for the human eye-brain system in creating a relaxing environment, a balance of light on walls and ceilings in relation to the task is also important from a contrast point of view.

Being exposed to a bright, uniform lighting level, whether it is a computer screen or an accounts ledger, will cause further strain to the eyes.

If you have ever watched a film on television with no lights on, you will know that the difference between the bright screen and dark surrounding walls means the eye is exposed to two hugely contrasting light levels and trying to adapt between these is difficult.

However, whilst creating an environment with visual contrast can be beneficial to users, we need to be mindful of the effects of inadvertent contrast within a space.

One area which is often overlooked is the colour temperature of fluorescent lamps; all too often we see occurrences of luminaires containing a mixture of different colour temperature lamps and rather than creating a comfortable and relaxing environment, this variance can be distracting to the people working under it.

A consistent approach in lamp type and colour temperature selection can ensure that the lighting appears the same visually in all areas of a building. This can help to develop a coherent maintenance programme as well as potentially reducing cost of maintenance through the possibility of bulk purchasing of replacement lamps.

The key element of the lighting design process is the selection of luminaires, lamps and controls to suit the application, the architectural demands of the space and the people that work and live in it.

Figure 31 *Light dark adaptation*

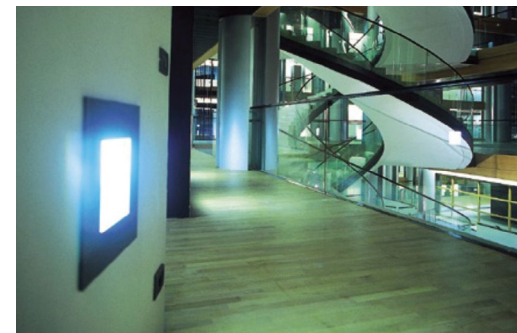

Did you know?

Light-dark adaptation is found in many situations – walking from bright sunlight into a dark room, driving through a tunnel.

These extremes of brightness cause a huge loading on our eye-brain system to adapt quickly and the same is true, even if in less extreme circumstances, in most workplaces.

Creating a good balance of light on the task – whatever that task is – the surrounding area and our overall visual field is crucial to user comfort.

Lighting design: In pictures

Figure 32 *Inappropriate luminaires for application modular lay-in in retail*



Image courtesy of JWSA

Figure 33 *Poor maintenance illustrated by mixture of lamps in luminaire*



Image courtesy of JWSA

Figure 34 *Poor LG3 application*



Image courtesy of Zumtobel

Figure 35 *Balance of light on walls and tasks*



Image courtesy of Zumtobel

Figure 36 *Good examples of daylighting in the work place*



Images courtesy of Thorn Lighting

Figure 37 *A well controlled office building with lights turned off at night*



Image courtesy of Zumtobel

Applications

How might lighting be effectively used in three categories of project: new construction, refurbishment and retrofit?

New construction projects

As the name suggests, this is a completely new lighting installation. Normally there will be a lighting expert on the design team.

When developing the brief for the lighting in a new building it is important to bear in mind the impact the design choices might have on the future operational costs, particularly maintenance. Detailed guidance on design considerations can be found in [on page 29](#).

Refurbishment

There is arguably two levels of refurbishment: treating the lighting project as a blank canvas or utilising some or all of the existing services. In the case of the former, the design objectives and considerations will be the same as for a new construction project.

In a lot of cases, however, the refurbishment programme will look to use some or all of the existing services. Whilst the principles of lighting design can still be followed, there may be some constraints such as ceiling types or layout.

It will be worth exploring all avenues before reaching decisions on the best way forward as it may prove more beneficial to go the extra mile with the refurbishment to achieve the optimum solution long term. See [How to implement lighting refurbishment \(CTL163\)](#).

Retrofit

A retrofit is a project where only the lighting is being reviewed and no other works are being actively pursued.

When considering an upgrade of out-dated or inefficient lighting, it is often tempting to go for a 'quick win'. Whilst this is possible, consideration should be given to the potential increased benefits of a deeper renovation. Quick wins are only a short-term fix. If the lighting is very inefficient then the benefits of a larger capital investment to an enhanced upgrade will be heightened and the savings on energy will quickly repay the investment.

Outlined over the next few pages is more detailed advice on each of these project types. The advice is intended to be generic so that it can be applied equally to a major commercial development, a small office or just a simple local shop.

There are a number of case studies which you should find inspirational!

New construction

A lighting scheme will be required as part of the original design.

Refurbishment

Lighting is often a significant element of the project. An opportunity to consider a new, more effective, lighting scheme.

Retrofit

A stand-alone project when the lighting in a building is out-dated and/or inefficient.

Although the lighting will always be considered for any new construction project or major refurbishment programme, it may also warrant a dedicated make-over, especially for older installations.

This section briefly outlines some of the main considerations and principles that should be followed when undertaking a project.

Legislation

There are over 30 European Standards which affect lighting in the UK. These cover a wide range of subject areas but the most relevant one is EN12464 which covers the lighting of workplaces. No European Standards are mandatory and there is no legal requirement for lighting other than that it must be "suitable and sufficient."

The Health & Safety Executive publishes guidance on minimum lighting levels and this can be downloaded from their [website](#). More detailed guidance can be found from the Society of Light & Lighting.

For new construction and significant refurbishment projects, the lighting must comply with the Building Regulations. It should be noted that these differ within the UK and the requirements for England & Wales differ from both Northern Ireland and Scotland.

For England & Wales, the section covering [lighting is Part L](#). In Northern Ireland, it is [Section F](#) and in Scotland, it is [Section 6 of the Building Standards](#). These all cover the conservation of fuel and power.

Figure 38 Lighter paint finishes reflect light better



Image courtesy of LPA Lighting

Maintenance

Before embarking on any new lighting project, it is worth first considering the maintenance of existing lighting and developing a schedule for maintaining this and any new lighting. The effectiveness of any lighting installation can be compromised without regular maintenance. This includes cleaning of luminaires, especially reflectors and panel diffusers. A fresh lick of paint can also make the world of difference, although dark colours should be avoided as they do not reflect light.

When lamps fail, replacement is generally carried out in two ways: spot replacing each one as it fails or bulk replacement. Which suits your own situation will usually depend on the size of the premises and ease of access but a one-off bulk replacement in an older installation may be worth considering.

Interior applications

If you have established, through this guide, that your lighting is out-dated or inefficient, then now is the time to consider your options.

There may be pressure to opt for a quick win and there is some merit in this, but it is worth considering a long term solution.

The two case studies following describe some of these solutions and of course, the primary consideration may be one of cost. However, you should consider not only the capital investment but also the associated running costs and long term benefits of each solution available.

The main consideration should be one of a return on investment, not just based on the cost of the capital investment but in terms of the benefits, tangible and otherwise that can be realised.

Having a clear picture of the options available, their associated costs and dividends will help the decision making process.

Case study

JM Henderson

JM Henderson took a two-pronged approach to their lighting, refurbishing the office lighting and upgrading the factory lighting.

In the office areas, they retrofitted new high frequency control gear and modern efficient fluorescent tubes into the existing light fittings.

In addition to lower energy costs and longer lamp life, the environment was improved for the staff as HF lamps do not flicker like the older ones.

In the factory they replaced the old sodium lighting with new luminaires containing fluorescent lamps. The old luminaires were mounted at high level and both the quality and level of lighting on the workshop floor was poor.

The new lighting produces crisp white light and is suspended at a lower height so in addition to increased light levels and lower energy use, they create a more productive and safer working environment.

Project cost:	£26,000
Energy reduction:	53 MWh
Financial saving:	£4,600
CO ₂ saving:	29 tonnes

Case study

Boon & Sons

Boon & Sons applied simple lighting controls to existing lighting in communal areas of shared office space with huge energy savings.

Tenants have access to the let office space 24-hours a day so lighting had been left on even when the area was unoccupied.

They installed fast-reacting motion sensors to provide light when clients require it, halting wasted energy and money lighting unoccupied areas.

The new motion sensors are in shared areas, such as kitchens, bathrooms, corridors and common rooms. Before they were installed, the 182 fluorescent lamps in these areas had been on 24 hours a day, 365 days of the year.

Now, when someone enters one of these areas, the sensors activate the lights and they stay on for as long as it remains occupied.

In addition to the energy savings, lamp life is prolonged and maintenance is reduced.

Project cost:	£5,200
Energy reduction:	36 MWh
Financial saving:	£3,600
CO ₂ saving:	20 tonnes

If you are considering a refurbishment of your existing lighting, it is helpful to know the scale of the opportunity that is available.

With most refurbishments, lighting is often only a component part of a larger programme of activities and there is merit in exploring every possibility before making a decision.

Replacing luminaires with new, more efficient or suitable ones is really just the first step. Controls again need to be a core consideration and although in many cases, both luminaires and controls can be upgraded without major re-wiring or impact on ceiling layout, there may be additional long-term benefits to further investment.

If the existing lighting isn't delivering the optimum performance for your use, then incorporating a level of re-design to the lighting scheme may reap greater rewards. This is often the case with inherited lighting schemes, so if you make this assessment before you proceed with any lighting upgrade, you may benefit greatly.

Case study

Maxim Logistics

Maxim Logistics replaced outdated fluorescent lighting with new, more efficient fluorescent luminaires and added lighting controls to reduce energy consumption by 40%.

By installing HF dimmable fluorescent luminaires, Maxim has been able to halve the number of luminaires in its main warehouse, without comprising the working environment.

Where there had previously been eight luminaires in each of the aisles, there are now just four. Two are on permanently, while the other two are lit at 10% with motion sensors to boost the light to 75% when the space is occupied.

Although there are fewer luminaires, the warehouse is now actually brighter, even with the two lamps on the dimmed setting, making the warehouse feel brighter and improving working conditions for staff, a great example of how saving energy can actually improve a working environment rather than compromise it.

Project cost:	£60,000
Energy reduction:	200 MWh
Financial saving:	£22,200
CO ₂ saving:	114 tonnes

Case study

Henderson Spar

A new lighting design with lighting controls for this convenience retail outlet delivers light when and where it's most needed. The total solution delivers a 25% energy reduction.

A new lighting scheme was designed for a pilot store with luminaires positioned centrally above the aisles. The specified luminaires allow light to be directed more specifically to where it is required.

The result is a store with increased light levels and an impressive 24.5% savings in lighting energy costs. The shop has a storage area and this area has been fitted with presence detectors on each pair of luminaires. The PIR sensors detect the presence of staff and automatically switch the lights on for a set period of time.

Further controls have been added with daylight sensors to control two different lighting circuits in the forecourt canopy and site lighting.

The solution is now being rolled across all stores as the existing lighting nears end of life.

Energy reduction:	25 MWh
Financial saving:	£2,250
CO ₂ saving:	13.5 tonnes

Case study

NG Bailey

NG Bailey use an office relocation to maximise availability of natural light and reduce demand for artificial lighting.

Daylight penetration is maximised in the centre of the open plan area through the use of roof lights and sun pipes into the toilet areas. Glare is controlled by occupant controlled interstitial blinds.

The lighting in the main offices is a mixture of LED and high frequency fluorescent fittings, controlled by a DALI dimming system with absence detection and daylight sensing. There is one detector for every four workstations and each luminaire can be adjusted individually to maximise control.

Lighting in the cellular offices and meeting rooms is manually controlled with scene setting lighting in the larger meeting rooms controlled by hand held devices and touch screens.

As it a new building, it is difficult to quantify the financial impact of all of the sustainability measures that have contributed to this BREEAM Excellent project but NG Bailey believe that the operational savings will pay back any additional energy investments and the staff report that they love the new building.

For new buildings and for refurbishment programmes which effectively allow for a blank canvas, there is opportunity to integrate the artificial lighting with the architecture of the building and to maximise the available daylight.

Controls linked to daylight puts less demand on the electric lighting and can lead to significant reductions in energy use. Of course, consideration must be given to the thermal impact, particularly for users by south-facing windows but horizontal blinds can reduce direct sunlight without compromising daylight in the space.

Controls are the key to maximum efficiencies so this is where it is crucial to consider who is going to be using the space and when they will be there. With this in mind, the right controls can be installed.

Whilst the lighting expert on the design team can advise on luminaires and light levels, it is important that the design meets your needs, whether that is in occupancy patterns or items being sold in a retail store.

Case study

Lomond National Park

A new purpose-built headquarters allows the National Park to provide a sustainable Building in the heart of the community.

The building was designed to maximise the use of natural light using the advantages of the orientation of the site with most workstations located on the North East side of the building to limit solar gain. The electric lighting is often not required as the daylight levels are so high.

The electric lighting is controlled automatically via occupancy sensors as well as daylight linking and the electric lighting only comes on if the light level falls below 250lux and all desks are provided with task lights that can increase lighting levels to 500lux if desired.

The meeting rooms have occupant control with manual light switches and staff are happy with the provision for dimming the light levels for presentations and video conferencing.

No blinds were installed in the original plan, but have now been ordered for the two main meeting rooms and some of the windows in the open plan area to provide shading.

Staff have welcomed the sustainable approach and have reported greater contentment and well-being.

Exterior applications

So far we have focussed on mainly interior applications but it is important to recognise the role of exterior lighting in the overall picture.

The same philosophy of design – the right light, in the right place, at the right time – and the equipment available applies equally to exterior applications.

The main applications for exterior lighting are:

- Car parks
- Security
- Architectural
- Amenity
- Sports
- Street lighting.

Some of these might be regarded as more important than others and the relevance of each will vary with each individual circumstance.

It is helpful to follow best practice and identify energy efficient solutions, irrespective of whether it is for new or existing lighting scenarios.

Arguably the most important consideration in exterior lighting is the impact it has in a wider context and this brings light pollution into context.

Light pollution can be categorised into three distinct areas: light which is directed into the sky, referred to as 'sky glow'; light which goes beyond the area it was intended to (light spill) and light which impacts onto other properties (light trespass).

You should keep all of these types of light pollution to a minimum. In fact, the most efficient exterior lighting will eliminate light pollution entirely meaning that all of the light is delivered to where it is required.

More detailed information on environmental considerations for exterior lighting can be found in the Society of Light & Lighting's Factfile 7 which can be downloaded for free at www.sll.org.uk

As well as ensuring you are getting light in the right place, it is equally important to only light at the right time and whilst it may be argued that some lighting, for safety or security for example, is on all night, the majority of applications should be more controlled.

Architectural, amenity and sports lighting should all be timer-controlled with a curfew, as there is little public benefit to this lighting beyond midnight. Car park and security lighting can be controlled effectively with presence detectors which could be combined with time clocks.

For street lighting, there is the opportunity with new technology to have lower light levels at some times of night which can respond to the traffic flow.

Exterior luminaires are usually sealed units in order to protect them from water damage, so retrofit lamp & gear solutions are not usually a viable option.

However, for existing installations, the latest technologies and improved luminaire design offer opportunity for energy savings through luminaire retrofit programmes.

LED technology is ideally suited to exterior lighting and can be used in a variety of applications. Their small size enables smaller luminaires to be used and they are ideal for architectural enhancement of buildings.

In civic and residential areas, renewal of luminaires, can not only reduce energy consumption, but create a more pleasant environment for people. Under white light, it is easier to identify people's faces and the perception of safety is increased.

The introduction of exterior lighting can also be of benefit – for example by creating pleasant and safer places for people to enjoy at night. See [How to implement external lighting \(CTL162\)](#).

Figure 39 Light pollution needs to be controlled



Image courtesy of Thorn Lighting

Figure 40 Buckingham Palace uses less than 3kW on exterior façade lighting



Image courtesy of JWSA

Case study

Central Bedfordshire Council

The Council have piloted a trial of LED luminaires to replace traditional street lighting. Traditional street lights are being replaced with LEDs to achieve significant wattage reduction, as well as reducing the maintenance burden of the highways team; 381 LED lanterns were installed across two pilot areas – one urban and the other semi-urban, using less than 50% of the installed energy load.

The instant light given by LEDs mean that full light output is achieved with no voltage spike or warm up period and using LEDs enables the standards to be met at a slightly lower light level than traditional sources would require.

As LEDs provide a more focused beam of light, they result in reduced trespass of light behind the column or into the sky although some residents felt preferred light onto the front of their homes for security reasons.

The Council now hopes to begin replacing life-expired lanterns with modern LED alternatives.

	Traditional	LED
Number of columns	373	381
Annual electricity consumption	119MWh	54MWh
Annual electricity spend	£10,710	£4,860
Annual CO ₂ emissions	64 tonnes	29 tonnes

Figure 41 National Theatre reducing lighting electricity use in many ways



Image courtesy of Philips Lighting

Figure 42 White light is commonly used for street lighting



Image courtesy of Thorn Lighting

Next Steps

There are many easy low and no-cost options to help save money and improve the operation of your lighting system.

Step 1. Understand your energy use

Find out what lighting you have, where it is installed and how it is used. Ask staff to report any lighting issues and act on any feedback. Check the condition and operation of lamps and luminaires and monitor how the lighting is used over, say, one week to obtain a base case against which energy efficiency improvements can be measured.

Step 2. Identify your opportunities

Compile an energy checklist of your lighting. Walk round your building and complete the checklist at different times of day (including after hours) to identify where energy savings can be made.

Step 3. Prioritise your actions

Draw up an action plan detailing a schedule of improvements that need to be made and when, along with who will be responsible for them. Short-term actions could include launching an awareness campaign and writing a usage policy;

long-term plans could include planning a major refit of lighting controls and zoning the lights.

Step 4. Seek specialist help

It may be possible to implement some energy saving measures in-house but others may require specialist assistance. Discuss the more complex or expensive options with an expert.

Step 5. Make the changes and measure the savings

Implement your energy saving actions and measure against original consumption figures. This will assist future management decisions regarding your energy priorities.

Step 6. Continue to manage your business for energy efficiency

Enforce policies, systems and procedures to ensure that your business operates efficiently and that savings are maintained in the future.

Related publications

“How to” guides

[How to implement lighting controls \(CTL161\)](#)

[How to implement external lighting \(CTL162\)](#)

[How to implement lighting refurbishment \(CTL163\)](#)

[How to implement LED lighting \(CTL164\)](#)

[How to implement T5 lighting retrofits \(CTL165\)](#)

Management guides

[Creating an awareness campaign \(CTG001\)](#)

Glossary

Ballast

A component of conventional control gear. It controls the current through the lamp, and is used with discharge lighting, including fluorescent, sodium, mercury and metal halide lamps. The term is sometimes used loosely to mean control gear. Also called a choke.

Choke

Alternative name for ballast.

Colour rendering

An indicator of how accurately colours can be distinguished under different light sources. The colour rendering index compares the ability of different lights to render colours accurately with the Ra measurement of 100 being 'ideal'. Colour rendering properties of a light source are specified by the colour rendering index (CRI).

Colour temperature

Also known as colour appearance, the colour temperature is the colour of 'white' the light appears. It is measured in Kelvin, and ranges from 1,800K (very warm, amber) to 8,000K (cool). 6,500K is daylight. There are many colours of 'white' available. For general use these are: a warm white (2,600 to 2,700 degrees Kelvin), a medium white (3,000 to 3,500 degrees Kelvin) and a cool white (4,000 degrees Kelvin).

Control gear

A 'package' of electrical or electronic components including ballast, power factor correction capacitor and starter. High-frequency electronic control gear may include other components to allow dimming etc.

CRI

Colour rendering index has been defined by the CIE (Commission Internationale de l'Eclairage). The CRI is specified in Ra. Good colour rendering equates to a high CRI (CRI 100 = daylight), poor colour rendering equates to a low CRI.

Diffuser

A translucent screen used to shield a light source and at the same time soften the light output and distribute it evenly.

Discharge lamp

A lamp which produces illumination via electric discharge through a gas, a metal vapour or a mixture of gases and vapours.

Efficacy (luminous efficacy)

The ratio of light emitted by a lamp to the power consumed by it, that is, lumens per Watt. When the control gear losses are included, it is expressed as lumens per circuit Watt.

Illuminance

The amount of light falling on an area, measured in lux. 1 lux is equal to one lumen per square metre.

Kelvin

A measure of colour temperature for lamps.

Light output ratio (LOR)

The ratio of the total amount of light output of a lamp and luminaire to that of just the bare lamp.

Luminaire

A light fitting and lamp including all components for fixing and protecting the lamps, as well as connecting them to the supply.

Lumen

Unit of luminous flux, used to describe the amount of light produced by a lamp.

Lux

An international unit of measurement of illuminance intensity of light.

Maintained illuminance

The illuminance averaged over the reference surface at the time maintenance has to be carried out (by replacing lamps and/or cleaning luminaires and room surfaces).

Ra

The colour rendering performance of a lamp is described by its general colour rendering index (Ra) which defines its ability to show surface colours accurately. It is described by a number – 100 is considered to be excellent, a value of 80 and above is good and appropriate for most situations where people are present. Where colour identification is important, a value of 90 or above should be used.

Rated average lamp life

The number of hours after which half the number of lamps in a batch fail under test conditions.

Re-strike

The time taken for a lamp to illuminate after being switched off and then on again.

Start-up

The time taken for a lamp to illuminate after being switched on from cold.

Lighting for task

The lighting provided for specific tasks within a lighting design. For example, task lighting design will depend on the particular tasks undertaken and the building lighting design.

Universal operating position

Refers to a lamp that can be oriented in any way without affecting light quality.

Go online to get more

The Carbon Trust provides a range of tools, services and information to help you implement energy and carbon saving measures, no matter what your level of experience.

Call us on 0800 085 2005 – Our experts offer independent, authoritative advice. Lines open 8.30am-5.30pm, Monday to Friday.

Website – Visit us at www.carbontrust.co.uk for our full range of advice and services.

➤ www.carbontrust.co.uk

Carbon Footprint Calculator – Our online calculator will help you calculate your organisation's carbon emissions.

➤ www.carbontrust.co.uk/carboncalculator

Publications – We have a library of publications detailing energy saving techniques for a range of sectors and technologies.

➤ www.carbontrust.co.uk/publications

Events and Workshops – We offer a variety of events and workshops ranging from a high level introduction to our services through to detailed technical energy efficiency training.

➤ www.carbontrust.co.uk/events

Energy Saving Plan – The Carbon Trust Advice Line can work with you to highlight areas for review within your organisation and can then provide you with a structured Energy Saving Plan. Call today on 0800 085 2005 and ask one of our advisors how an Energy Saving Plan could help your organisation cut carbon emissions and save money.

Cut Carbon, Cut Costs Online Training Tool – This tool gives you an introduction to energy saving and helps you create a personalised action plan for your site, estimating the cost and carbon savings you could make in your workplace.

➤ www.carbontrust.co.uk/onlinetraining

Case Studies – Our case studies show that it's often easier and less expensive than you might think to bring about real change.

➤ www.carbontrust.co.uk/casestudies

Energy Efficiency Financing – Investing in energy efficient equipment makes sound business and environmental sense, especially with the easy, affordable and flexible Energy Efficiency Financing scheme brought to you by Carbon Trust Implementation and Siemens Financial Services.

➤ www.energyefficiencyfinancing.co.uk

The Carbon Trust is a not-for-profit company with the mission to accelerate the move to a low carbon economy. We provide specialist support to business and the public sector to help cut carbon emissions, save energy and commercialise low carbon technologies. By stimulating low carbon action we contribute to key UK goals of lower carbon emissions, the development of low carbon businesses, increased energy security and associated jobs.

We help to cut carbon emissions now by:

- providing specialist advice and finance to help organisations cut carbon
- setting standards for carbon reduction.

We reduce potential future carbon emissions by:

- opening markets for low carbon technologies
- leading industry collaborations to commercialise technologies
- investing in early-stage low carbon companies.

www.carbontrust.co.uk
0800 085 2005

The Carbon Trust receives funding from Government including the Department of Energy and Climate Change, the Department for Transport, the Scottish Government, the Welsh Assembly Government and Invest Northern Ireland.

Whilst reasonable steps have been taken to ensure that the information contained within this publication is correct, the authors, the Carbon Trust, its agents, contractors and sub-contractors give no warranty and make no representation as to its accuracy and accept no liability for any errors or omissions. Any trademarks, service marks or logos used in this publication, and copyright in it, are the property of the Carbon Trust. Nothing in this publication shall be construed as granting any licence or right to use or reproduce any of the trademarks, service marks, logos, copyright or any proprietary information in any way without the Carbon Trust's prior written permission. The Carbon Trust enforces infringements of its intellectual property rights to the full extent permitted by law.

The Carbon Trust is a company limited by guarantee and registered in England and Wales under Company number 4190230 with its Registered Office at: 6th Floor, 5 New Street Square, London EC4A 3BF.

Published in the UK: December 2011.

© The Carbon Trust 2011. All rights reserved.

